

Our Pride ...

KCP75ZS170

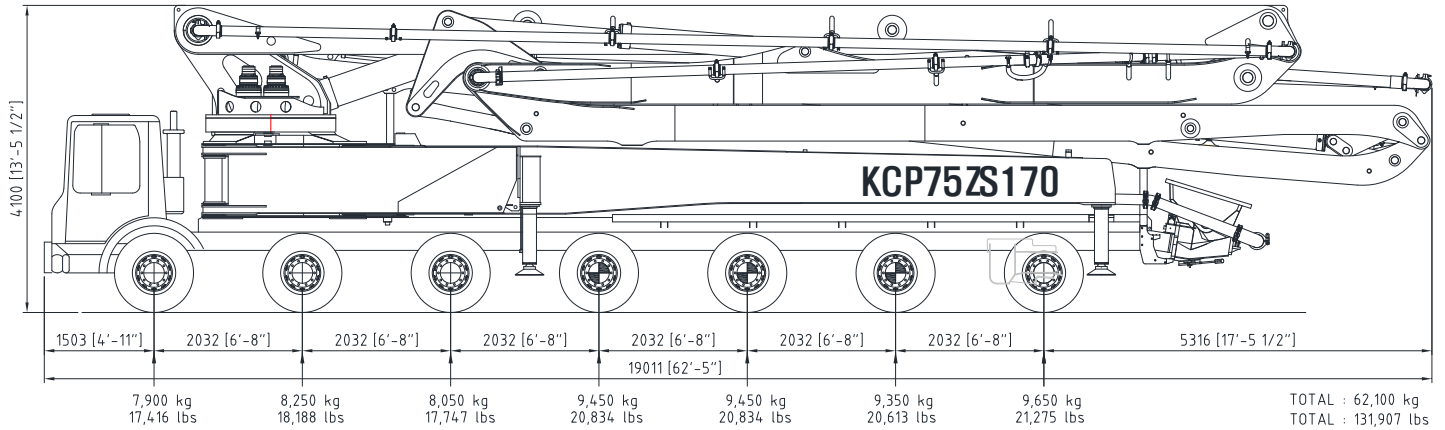

▣ Boom specifications

Vertical reach	75.1 m	(246' 5")
Horizontal reach	71.9 m	(235' 10")
Reach from front of truck	68.6 m	(225' 1")
Unfolding height	18.3 m	(60')
Section articulation	92°/180°/200°/180°/200°	
Rotation	370°	
246' 5" Delivery line	125 mm	(5")
Proportional boom	Yes	
End hose length	3.5 m	(11' 6")
Outrigger spread-front	15.1 m	(49' 6")
Outrigger spread-rear	14.8 m	(48' 7")
Max. outrigger weight	57,000 kg	(125,663 lbs)

▣ Pump specifications

Maximum output	170 m ³ /h	(222yd ³ /hr)
Concrete cylinder	Ø230×2100	(9"×83")
Stroke per minute	32	
Concrete pressure	95 bar	(1,377psi)
Hopper capacity	0.6 m ³	(21ft ³)
S-tube	Ø220×Ø180	(9"×7")
Hydraulic pump	Rexroth A20VLO190	
Cycling system	Hydraulic with manual overrides	
Max. aggregate size	40 mm	(1.5")

- ◎ Truck specifications : MACK
- ◎ Maximum theoretical values listed.
- ◎ Photos and drawings are for illustrative purpose only
- ◎ Right to make technical amendments reserved

▣ Working diagram

